

Backview

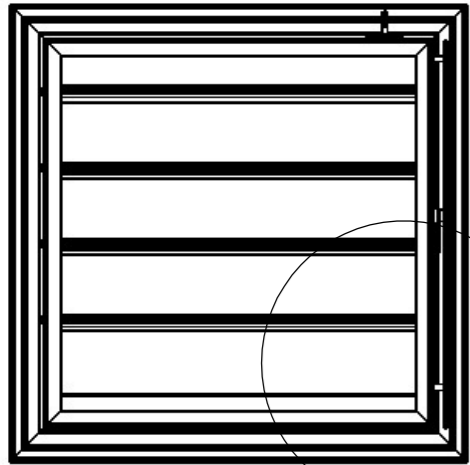

A

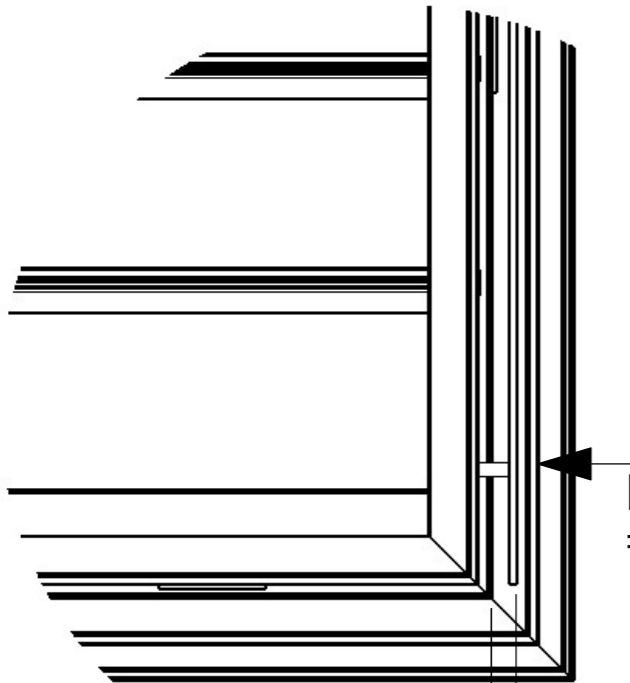
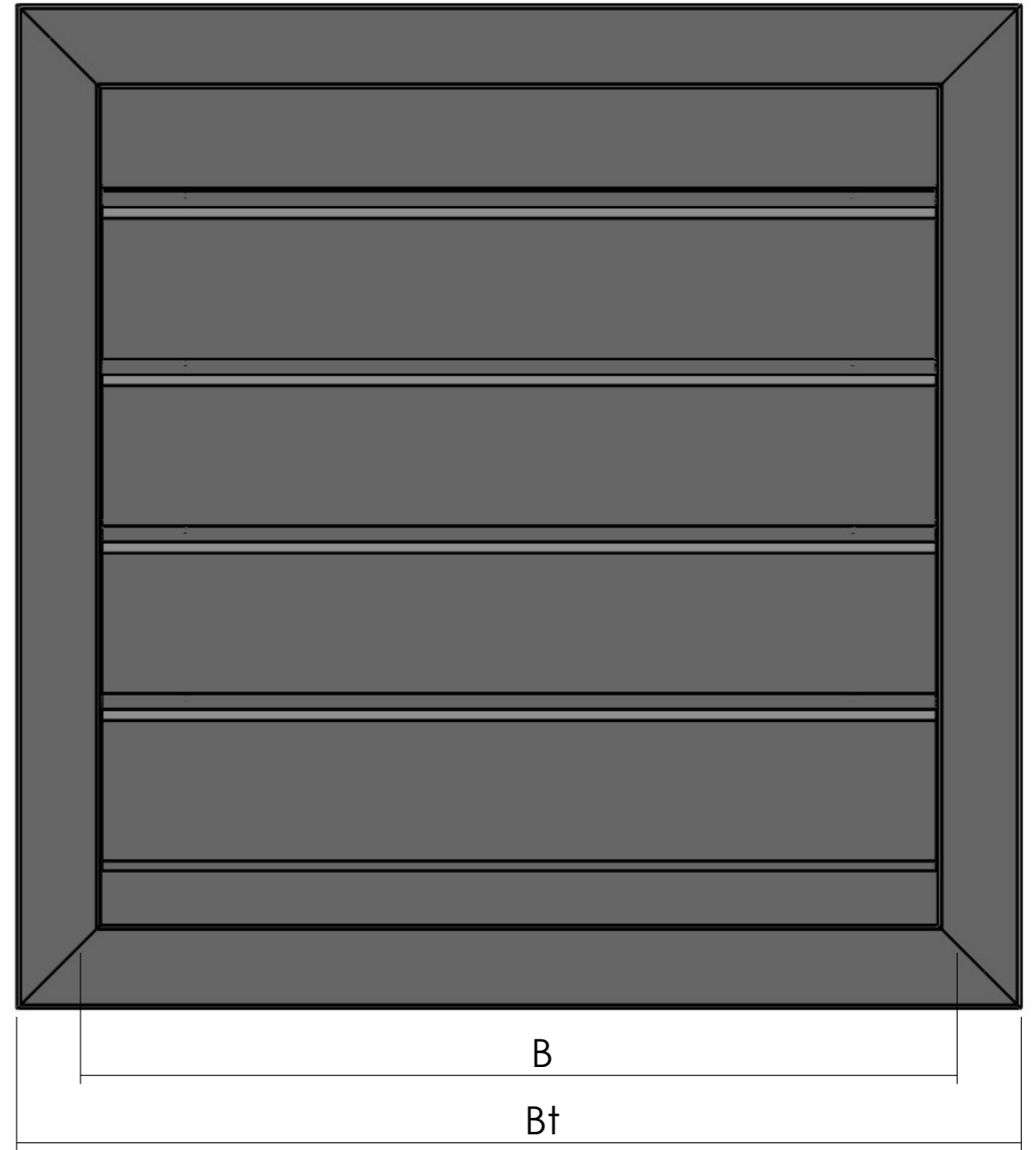
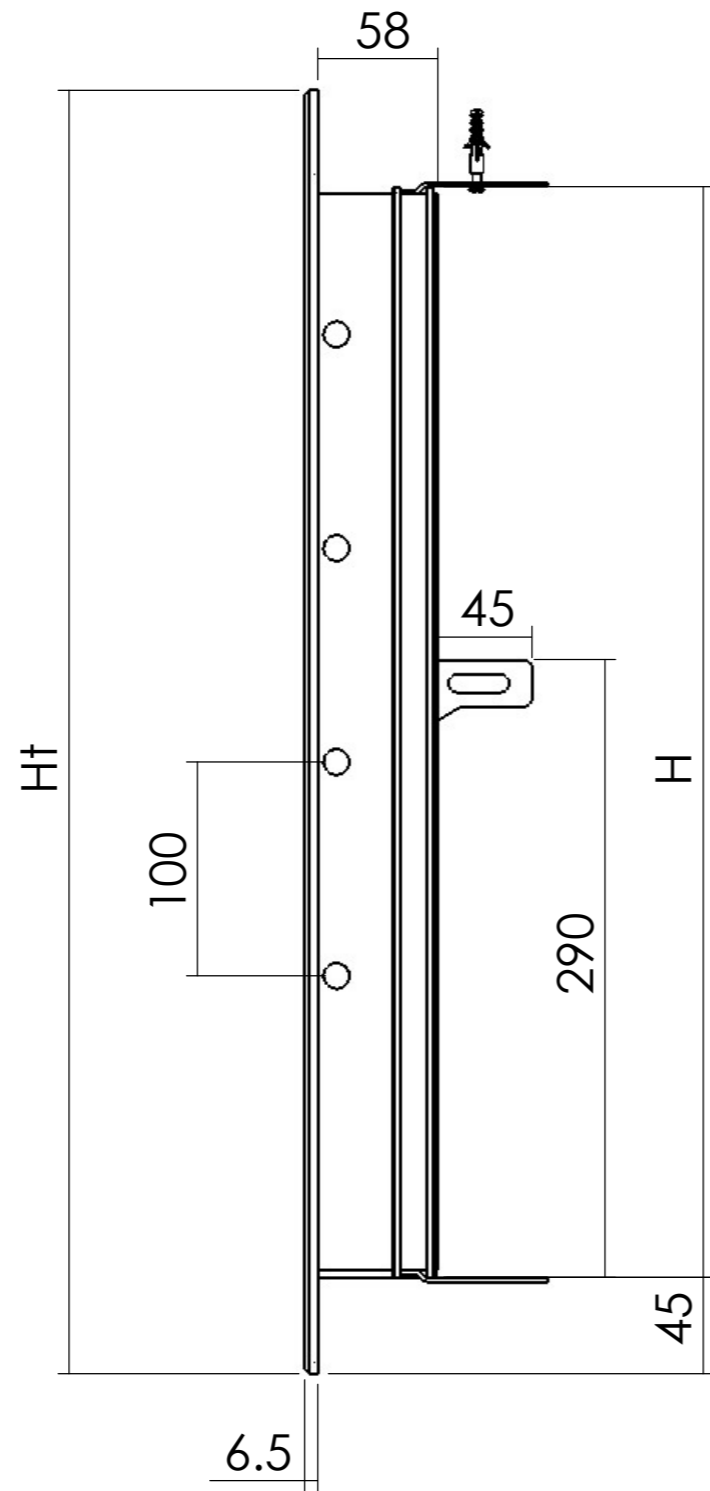

Extra installation width due to adjustment system = +18 mm

B

18

DETAIL A



	Naam	Handtekening	Datum	Materiaal:	Naam tekening:	
Getekend	Ing. T.Doornein		16-11-2020		<b>SG05</b>	
Gecontroleerd				Gewicht:	Tolerantie: Volgens GAVO AT01	A4
Goedgekeurd				SCALE:1:5	SHEET 1 OF 3	

### Default

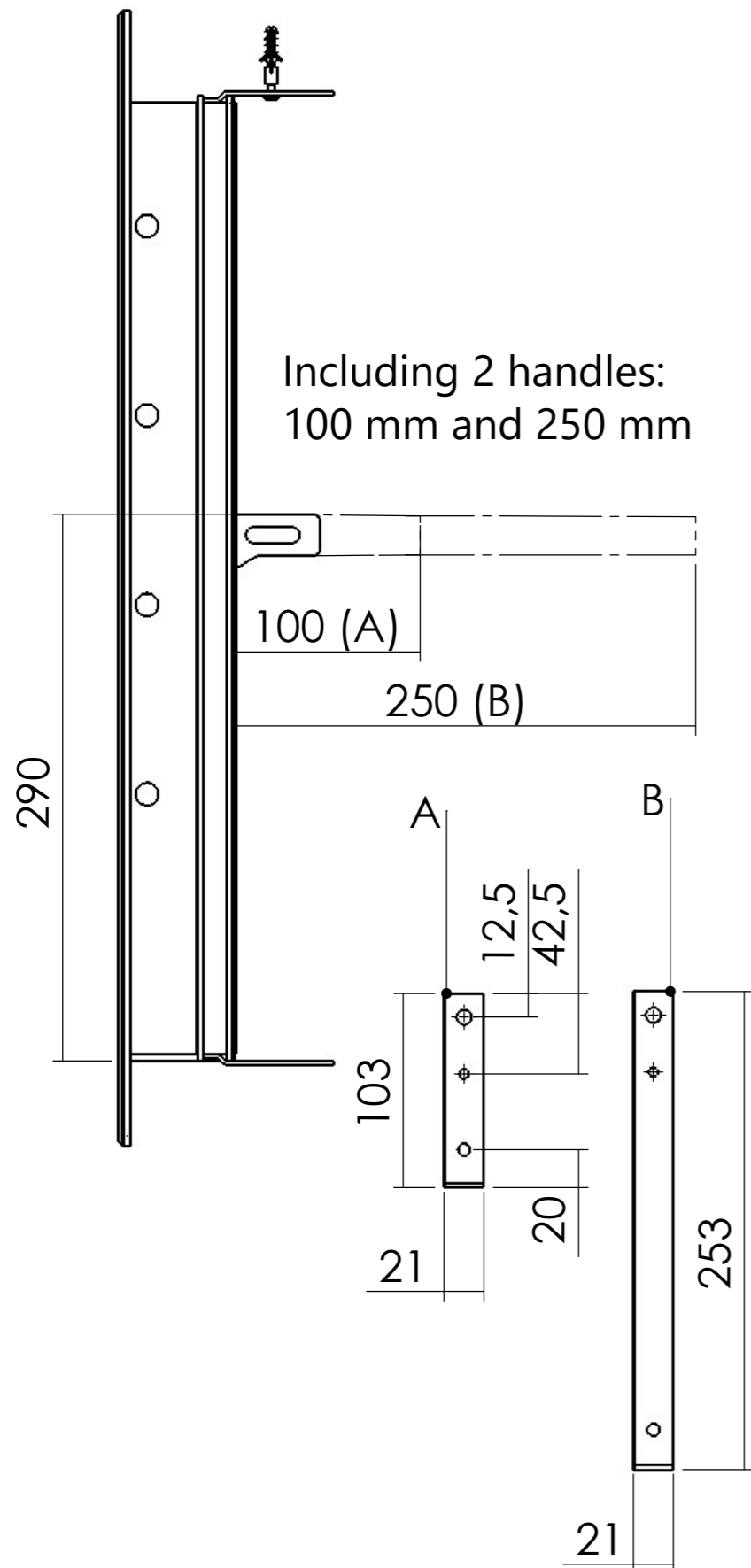

Including 2 handles:  
100 mm and 250 mm

### Motor

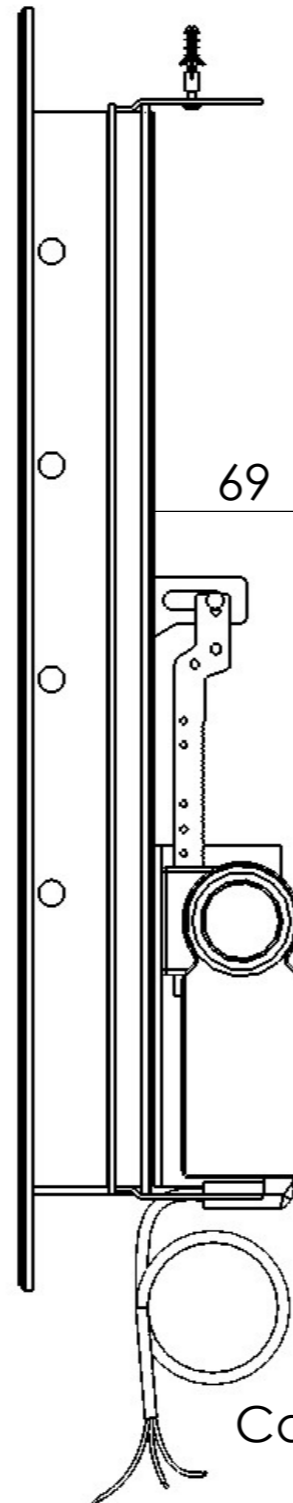

Elektromotor BELIMO  
AC/DC 24V or AC 230V  
50/60 Hz

Cable length = 1 meter

### Chain

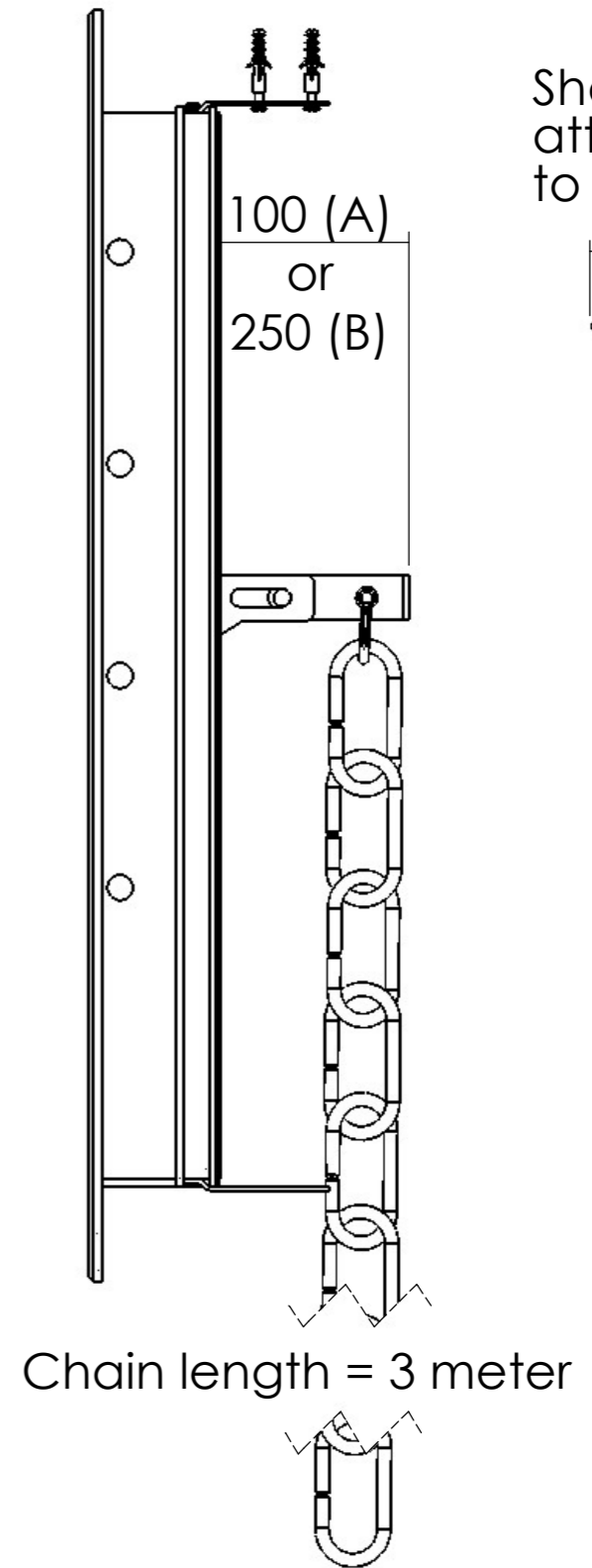

Shackle for chain  
attachement  
to wall:

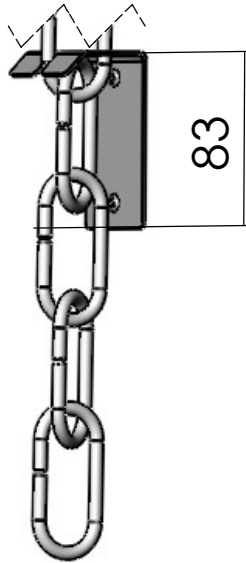
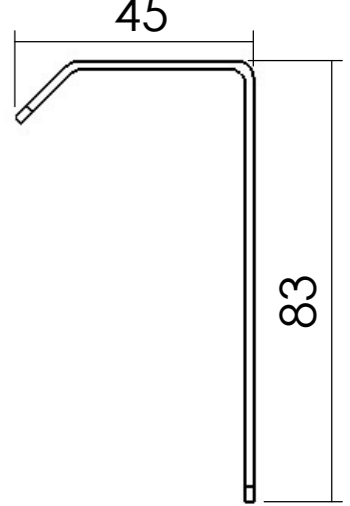

Chain length = 3 meter



	Naam	Handtekening	Datum	Materiaal:	Naam tekening:	
Getekend	Ing. T.Doornein		16-11-2020		<b>SG05 options</b>	
Gecontroleerd				Gewicht:	Tolerantie: Volgens GAVO AT01	A4
Goedgekeurd				SCALE:1:5	SHEET 2 OF 3	

Lever

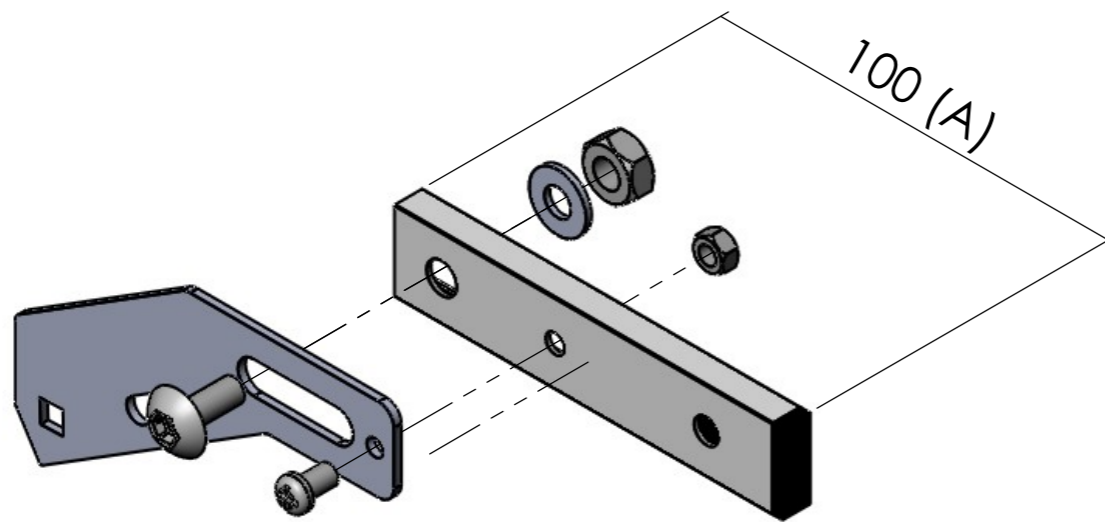

Fixing hooks

Step 1:

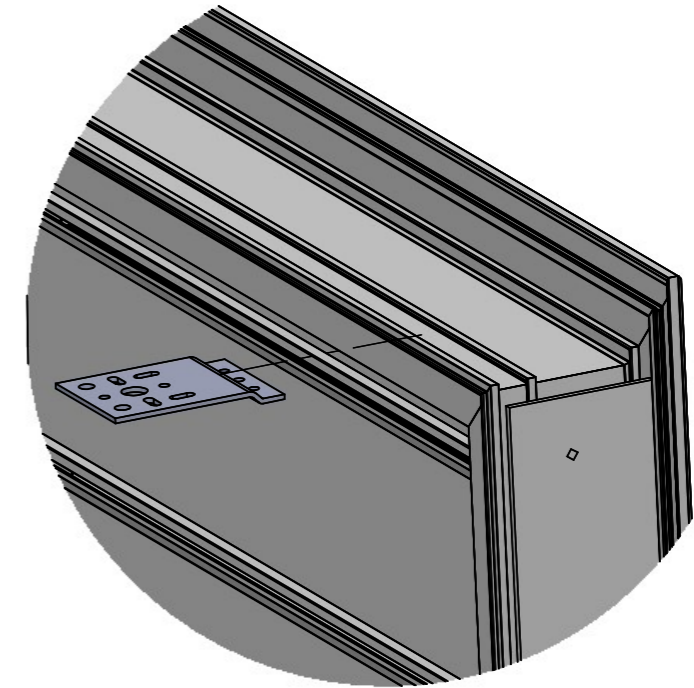

Step 2:

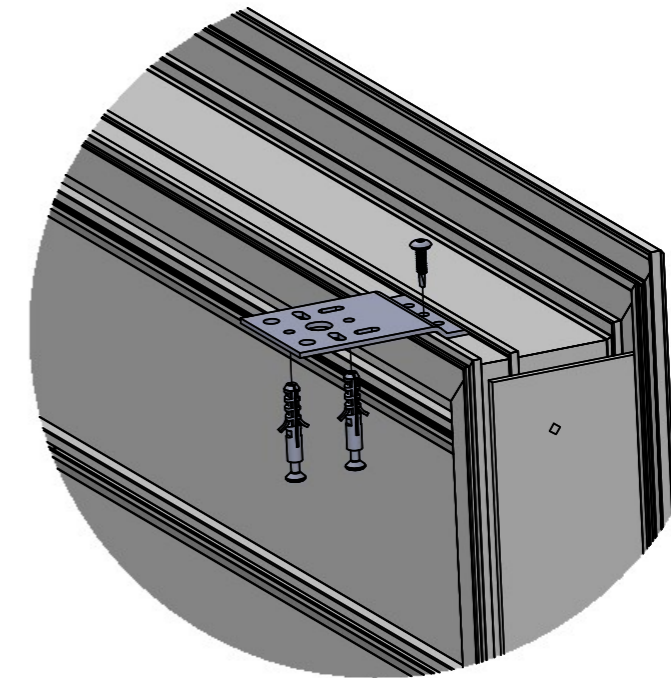

**GAVO VENTILATIE**

**GAVO CONCEPTS**

	Naam	Handtekening	Datum	Materiaal:	Naam tekening:	
Getekend	-		16-11-2020		-	
Gecontroleerd				Gewicht:	Tolerantie: Volgens GAVO AT01	A4
Goedgekeurd				SCALE:1:2	SHEET 3 OF 3	